Chapter 1 Control system function	2
1.1 Base function.....	2
1.2 Special function.....	4
1.3 Safety protective functions.....	6
1.4 Optional functions	6
Chapter 2 Component and installation of control system	7
2.1 Component of control system	7
2.1.1 Flow figure and principle of system.....	7
2.1.2 Component of control panel	7
2.1.3 Definition of input and output terminal	9
2.2 Installation of control system	14
2.2.1 Installation of TJ/TT5 1 Tf18.9029 0 TD0 Tc0 Tw0	5.70

	Automation Running (no attendant)		<ol style="list-style-type: none"> 1). Opens the door automatically after landing; 2). Closes the door automatically after time delay; 3). Closed the door by hand previously (after the door fully opening but before the time delay); 4). Registers the car call automatically; 5). Lands automatically if there is same directional landing call; 6). Lands automatically toward the highest (or lowest) reverse directional landing call 	<ol style="list-style-type: none"> 1). Turn all the “normal/inspection” switch (car top, COP and control panel) to “normal” position; 2). Turn the “automation/attendant” switch to “automation” position.
	Attendant Running		<ol style="list-style-type: none"> 1). Opens the door automatically after landing; 2). Closed the door by attendant’s hand; 3). Registers the car call automatically; if there is landing call, the relative car call button will flash; 4). Lands automatically if there is same directional landing call. 	<ol style="list-style-type: none"> 1). Turn all the “normal/inspection” switch (car top, COP and control panel) to “normal” position; 2). Turn the “automation/attendant” switch to “attendant” position.
	Inspection Running	For commissioning, maintenance	When the system is in inspection mode, if keep pressing “up” or “down” push button, the elevator will move up or down with inspection speed, and stop once release.	The “normal/inspection” switches are separately located on car top, car and control panel which their priority is car top>car>control panel, for example, if car top “inspection” switch is on, it is impossible to move the elevator by pressing the “up” or “down” button in COP and control panel
	Opens the door automatically once it’s powered on	Opens the door automatically	On the “automation” mode, if the car is at door zone, the the door will automatically open once the elevator is powered on.	This function is performed only on “automation” mode.

	Delay time setting for automatical closing door (time of keeping door open)	Keeping door open	After the door completely opening, it keeps opening and closes the door automatically after delay time.	1). Delay time can be set as a parameter (T); 2). If it only stops for landing call, the delay time should be T-2 seconds; 3). If it only stops for both of car call and landing call, the delay time should be 2T seconds.
	Door open for local zone landing call	Door open for landing call	The elevator door is closing or already closed but it does not start, if there is landing call of local zone (this call is the same direction with the pre-confirmed direction), then the door will reopen.	The delay time is the same as its setting value; if the landing call is opposite with the pre-confirmed direction, then the door will not reopen unless the direction is changed.
	Safety edge or light curtain protection	Safety for door closing	Touching the safety edge or obstructing the light curtain while the door is closing can stop closing at once and the door will reopen automatically.	Reclose the door after the safety edge or light curtain being recovered.
	No closing door once over load	Wait for reducing weight	While over load, the elevator will not close the door, and will lighten the alarm LED and sound the buzzer, and will not start.	Recover to the normal state automatically once over load disappears.
	By pass when full load	Directly lands to the nearest floor registered by car call	While full load, the elevator performs only as per car calls, not landing calls.	Recover to the normal state automatically once full load disappears.
	By pass controlled by attendant	VIP running	While attendant running, if press the "by pass" button, the eleva	

	Parking control	Stop running	<p>After switching off key switch, the elevator will enter parking state.</p> <p>1). If the elevtor is running and there are car calls registered, then it will not respond any landing call, and will serve the registered car calls, then return to the parking floor (the parking floor can be set)</p> <p>2). If there is not registered car call, it will return the parking floor directly.</p> <p>3). After parking the elevator will:</p> <p>a. no longer respond any call;</p> <p>b. close the door automatically 10 seconds later, and switch off the indication of COP and all indicators</p> <p>c. open the door again if you keep press the “open” button, but it will reclose again after 10 seconds.</p>	<p>1). If the elevator is in inspection mode while the key switch is switched off, the elevator will not return to the parking floor, other functions will be kept;</p> <p>2). During parking state, the CPU is still working, so once the key switch is switched on, the elevator will quit the parking state at once, and start normal running.</p>
	Leveling a floor after fault	For rescuing passenger	cti0.62	15JET0..1(U

	Repeat door closing		After outputting the door closing dictate, if the door interlock circuit is not switched on during the stipulated time, then the door reopens and closes again.	If it repeats 5 times and the door interlock circuit is still "off", then the elevator stops running, and shows the fault code on the LCD of operator.
	Make car calls in machine room	For commissioning	pushing-7.1(button on)TJET0.953 g25	50.44 671.780

	electronic noise at input port	influence of electronic noise automatically at input port which comes from hoistway wiring.	input signals and show the conclusion at LCD, which can direct the technician to arrange traveling cable, hoistway wiring and earthing as best as they can, try to eliminate the electronic noise caused the parallel connect between hoistway wiring, traveling cable and the input port of PCB, therefore avoid the trouble of wrong display, leveling failure and so on.	input port.
	Multi-function input and output	Function setting of input and output ports	It can define the function of input and output ports at will	

	Safety circuit protection	The elevator will stop at once if the safety circuit is switched off.
	Door interlock protection	The elevator will run only when the door interlock circuit is ok, if the door interlock circuit is switched off or unreliable while it's running, it will stop at once.
	Main contactor protection	The system can check the action reliability of main contactor in motor circuit, the elevator will stop at once if any trouble occurs (the contacts are not switched on when power is on, or not released when power is off)
	Brake protection	Monitor the action of brake by the checking switches at brake arms, once the brake acts not according to the request of system, the elevator will be forbidden to start.
	Terminal deceleration and floor display modification	Once the system gets the signal from terminal switch while running, the elevator will be forced to decelerate and modify the floor display automatically.
	Limited protection	Once the system gets the signal from limited switch, the elevator will stop at once.

The system flow figure refers to figure 2-1. The control unit of system is 32 bit microprocessor BL-2000-BHT. This unit adopts parallel collective mode to collect the signals from COP, HOP, hoistway and safety circuit, and

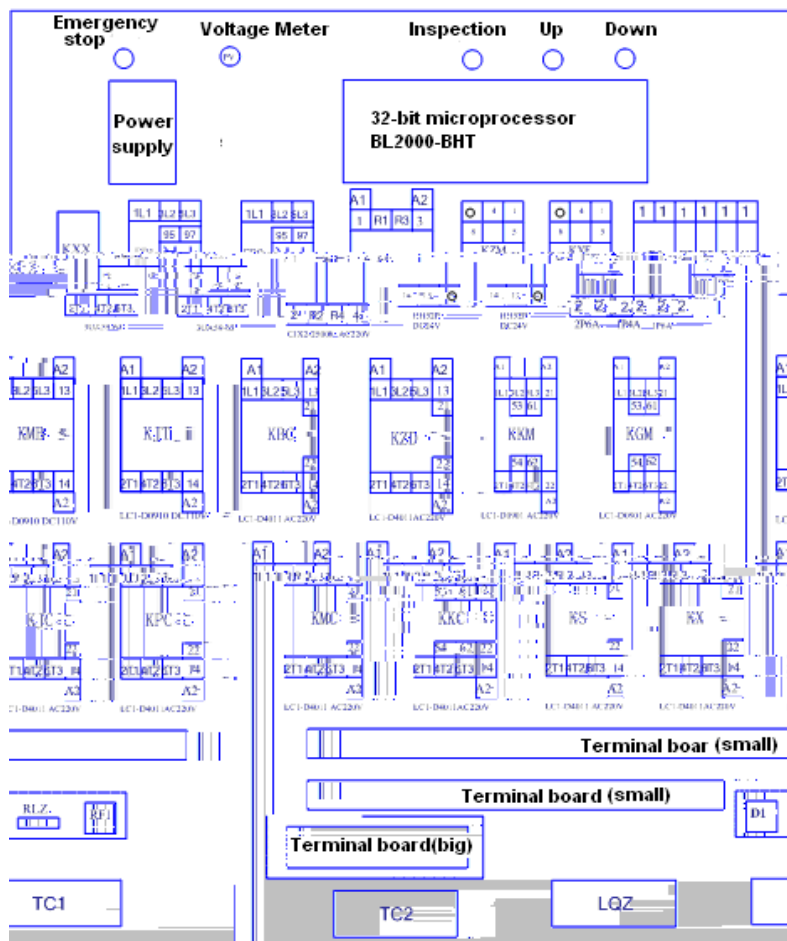

Figure 2-2 AC-2 speed control panel components layout

Discription of components

- 1). Inverter : Not applicable
- 2). TC1 Main control transformer. It provides power supply for whole system, its input is AC380V, and outputs are AC220V and AC110V two parts.
- 3). Power unit: The power supply for control unit, its input is AC220V, and outputs are DC24V and DC 5V two parts.
Warning: The powe unit shold be reliably earthed, otherwise it migh affect the control unit.
- 4). KXX Phase protective relay.
- 5). F1~F4 Breaker. F1: For main control power supply; F2: For 110V control power supply; F3: For 24V control power supply; F4: For 220V illumination power supply.
- 6). KMC: Main contactor. For the inverter power supply, once this contactor acts, the inverter gets the power supply.
- 7). KDY: Assistant contactor. The connection between inverter and motor, once this contactor acts, the motor gets connection to the inverter.
- 8). KJT: Safety contactor. It acts once the safety circuit is switched on.
- 9). KMB: Door interlock contactor. It acts once the door interlock circuit is switched on.
- 10). KLZ: Brake contactor. The brake opens once this contactor acts.
- 11). KKM: Door open contactor. The door operator works for opening door once this contactor acts.
- 12). KGM: Door close contactor. The door operator works for closing door once this contactor acts.
- 13). RZD: Brake resistance
- 14). TZD: Overheat protective switch. For monitor the temperature of brake resistance.
- 15). RF1: Rectifier. Output DC 110V

- 16). D1: Diode for brake discharging.
- 17). RLZ: Resistance for brake discharging.
- 18). KZM: Illumination relay. Once this relay acts, the illumination is switch off.
- 19). KXF: Fireman mode relay. The elevator will be I fireman only when this relay acts.(Optional)
- 20). Microprocessor control unit BL-2000-BHT

Microprocessor control unit is the center of the system, all control references are from this unit, and its layout is as follow:

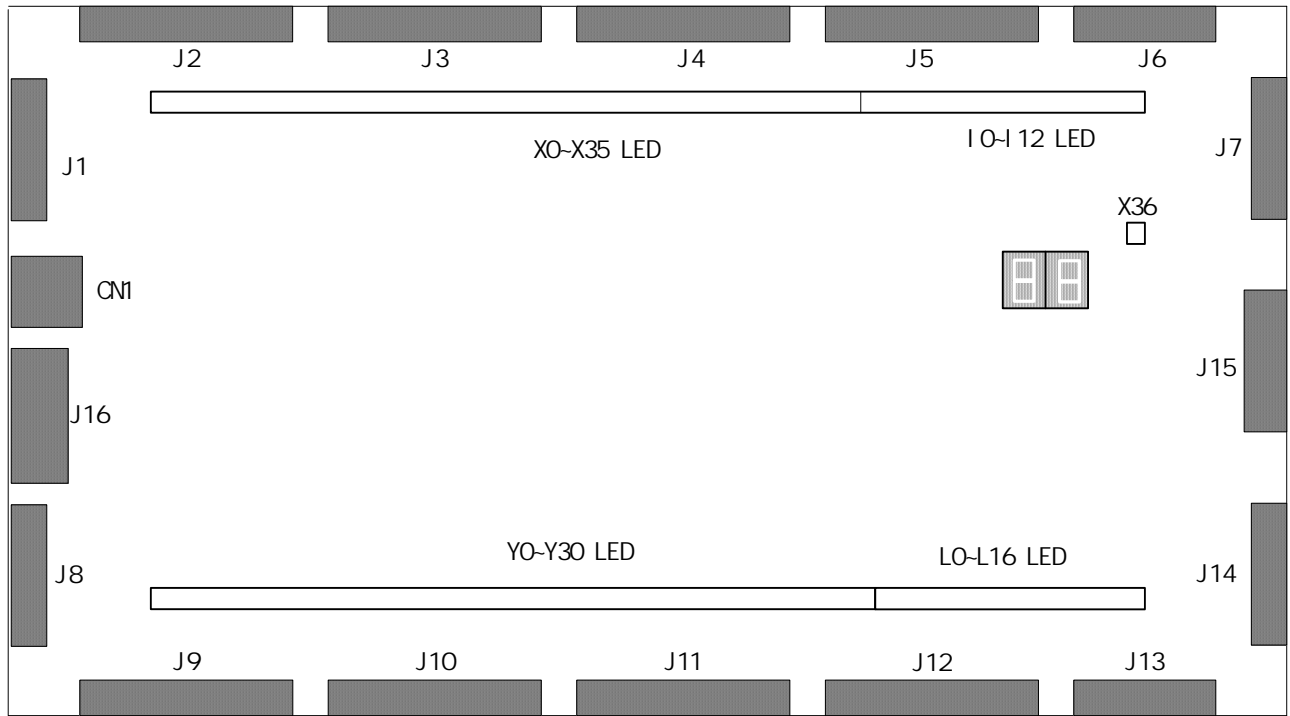

Figure 2-3 Layout of BL2000-BHT

Thereinto J15 is expandable port, CN1 is

J2_10	X9	C	SXH: Down speed change switch input
J3_1	X10	C	SJT: Safety circuit input
J3_2	X11	C	SMB: Door interlock input
J3_3	X12	C	NO
J3_4	X13	C	SXF: Fireman switch input
J3_5	X14	C	SMS: Inspection up- running input
J3_6	X15	C	SMX: Inspection down-running input
J3_7	X16	C	SSDZ: Up terminal switch input
J3_8	X17	C	SXDZ: Down terminal switch input
J3_9	X18	C	KPC: Power supply input
J3_10	X19	C	SKM: Door open signal input
J4_1	X20	C	SGM: Door close signal input
J4_2	X21	C	SKMW: Door open limited switch input
J4_3	X22	C	SGMW: Door close limited switch input
J4_4	X23	C	STAB1: Door safety edge 1
J4_5	X24	C	SDS: Key switch input
J4_6	X25	C	SCZ: Overload input
J4_7	X26	C	SMZ: Full load input
J4_8	X27	C	SKX/SKS: Feedback input of direction contactor
J4_9	X28	C	NO
J4_10	X29	C	SKYC: Door open time extention input
J5_1	X30	C	SZH: Attendant signal input
J5_2	X31	C	SZS: By pass signal input
J5_3	X32	C	Brake inspection switch input
J5_4	X33	C	Overheat switch input
J5_5	X34	C	SKM2: Door open signal input 2 (for opposite door)
J5_6	X35	C	SGM2: Door close signal input 2 (for opposite door)
J5_7	I0	C	Car call 1
J5_8	I1	C	Car call 2
J5_9	I2	C	Car call 3
J5_10	I3	C	Car call 4
J6_1	I4	C	Car call 5
J6_2	I5	C	Landing call up 1
J6_3	I6	C	Landing call up 2
J6_4	I7	C	Landing call up 3
J6_5	I8	C	Landing call up 4
J7_1	I9	C	Landing call down 2
J7_2	I10	C	Landing call down 3
J7_3	I11	C	Landing call down 4
J7_4	I12	C	Landing call down 5
J7_5	X36+	B	Door interlock circuit + 110V—220VAC
J7_6	X36-	B	Door interlock circuit - 110V—220VAC

J7_7	24V2	24V Input
J7_8	5V	5V Input
J7_9	GND1	24V,5V Earthing
J7_10	24V1	COM of input (24V)

Input type
(electrical drawing)

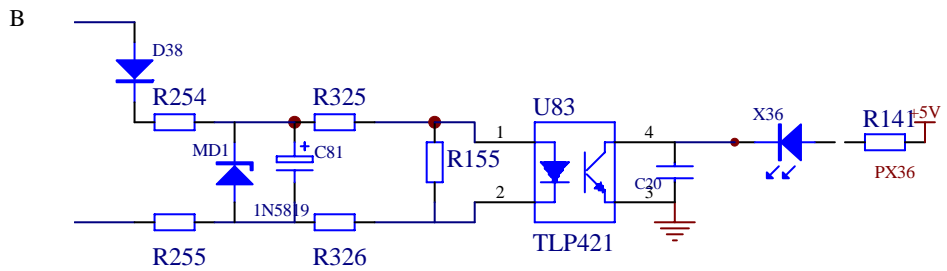
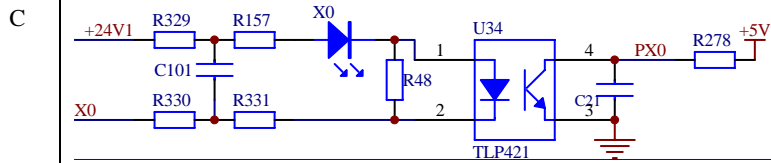
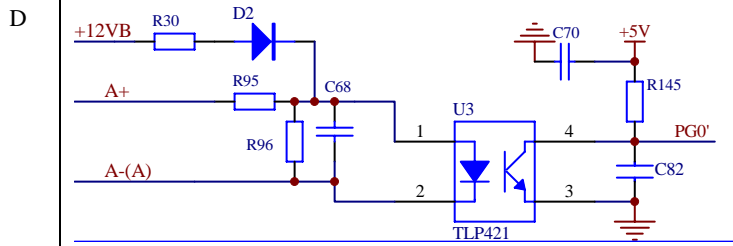

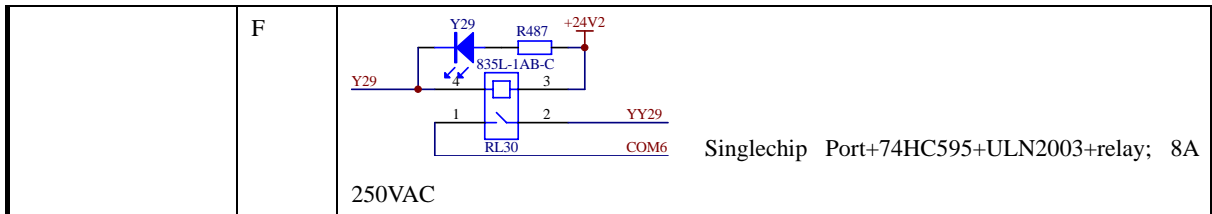

33 Extension unit BL2000-EBA

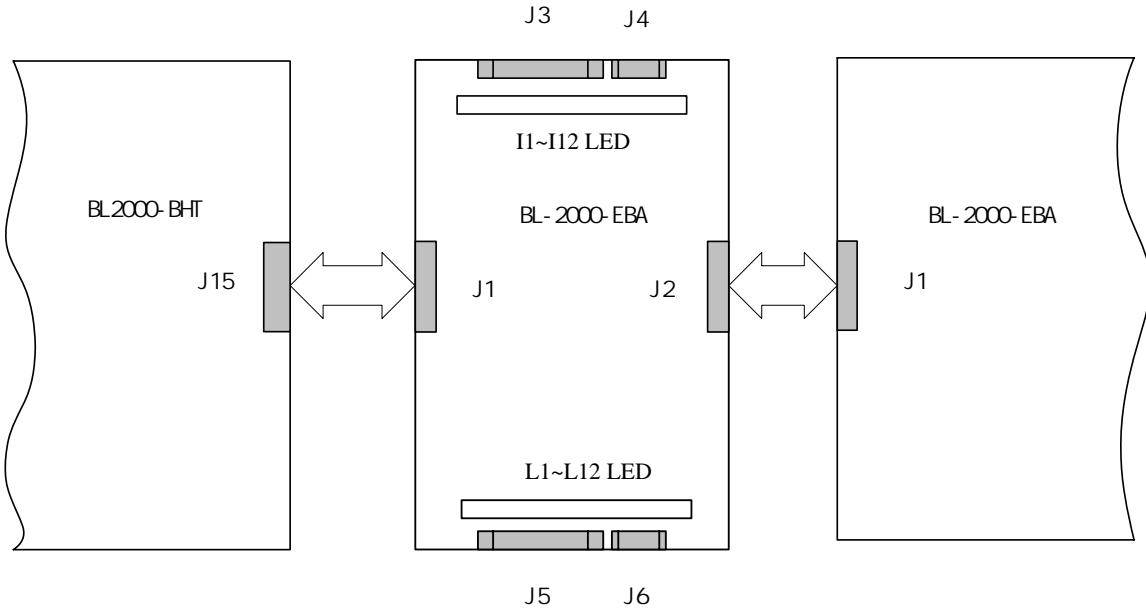

Figure 2-4 Extension unit BL-2000-EBA layout

BL2000-EBA is the extension unit with single CO

	J4_4	No
	J4_5	No

Installation and wiring of the hoistway and travelling cables should according to the electrical drawing.

While welding is processed, the nature wire of welding machine must be connected reliably with the component which will be welded, it's strictly forbidden to make use of the cable's earth wire as the nature wire of welding machine, otherwise the cable will be burnt.

There are seven main circuit terminals in control panel, thereinto U1, V1, W1 are the 3 phase power supply input. The power supply which comes from main power switch is

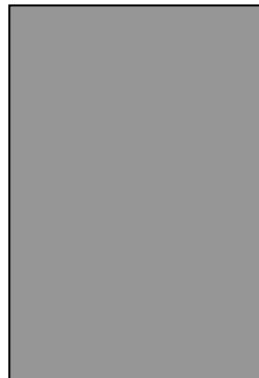

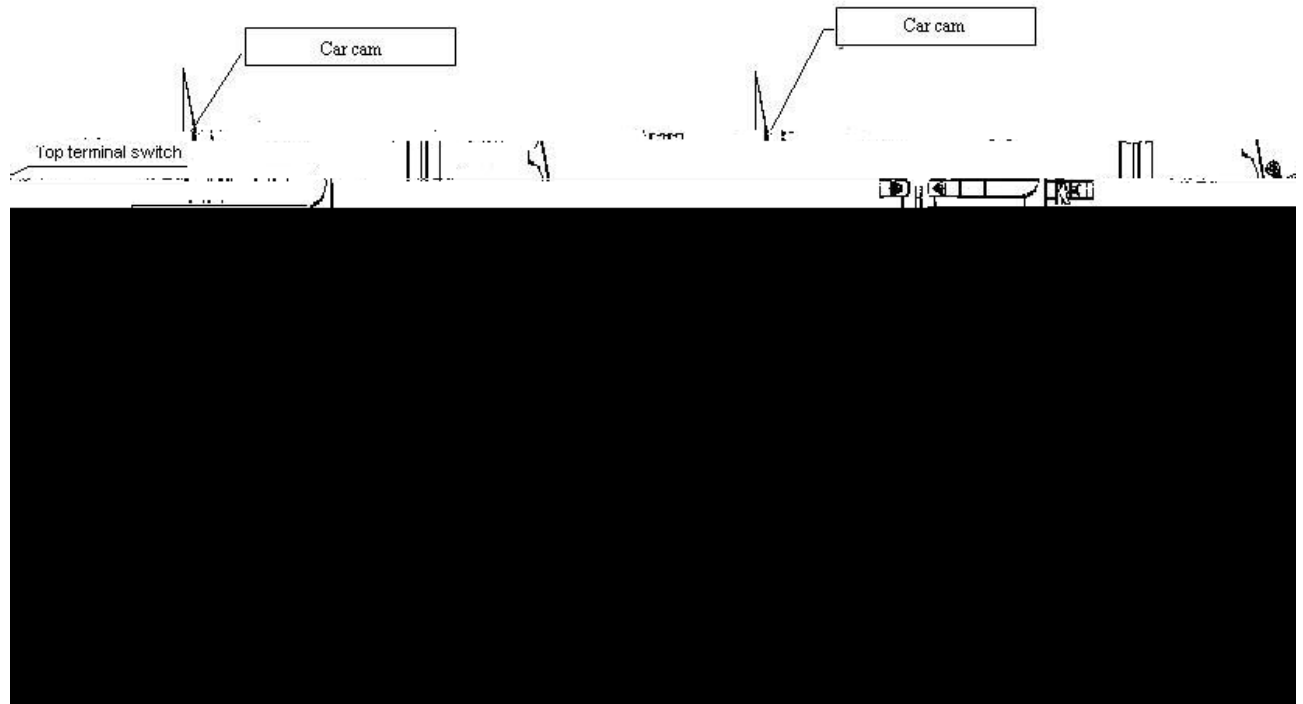

Figure 2-6 Top/bottom terminal installation figure

Elevator Speed	H
0.5m/s	0.8m
1.0m/s	1.5m

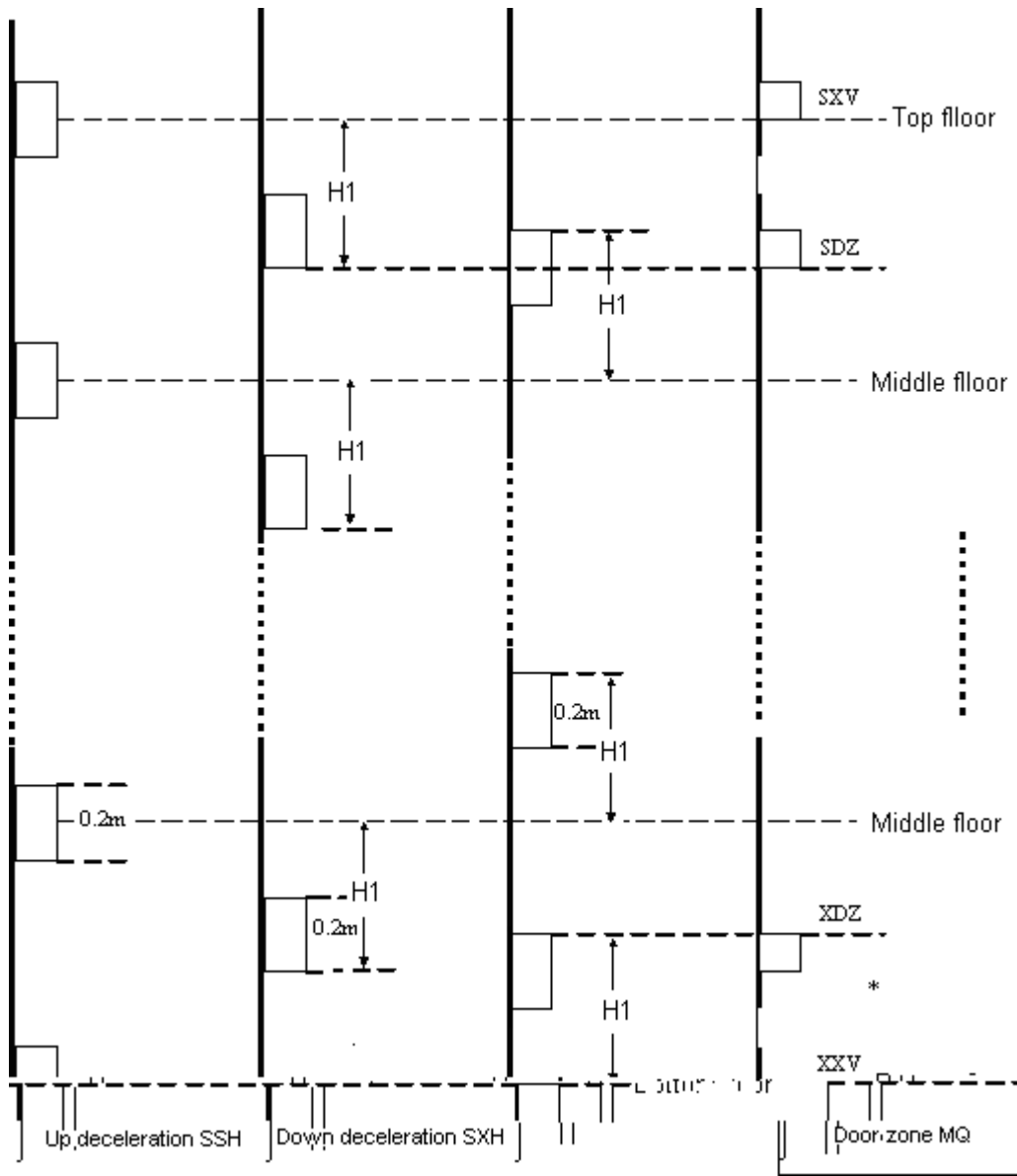

Figure 2-7 Deceleration switch position figure

Elevator Speed	H 1
0.5m/s	0.85m
1.0m/s	1.55m

The hand operator's LCD indicator provides a good communication interface for technicians to observe the system and set the parameters. Details are as follows:

- 1). Monitor the state of elevator: automation, inspection, attendant, fireman, locking, etc;
- 2). Observation: I/O port, fault code, landing call, car call, etc;
- 3). Parameter setting: base parameter, running parameter, special parameter, etc;
- 4). Parameter saving;
- 5). New password setting.

Note: this operator is an optional part.

Refer to the following figure, there are six keybuttons on operator, their layout and definition are as follows:

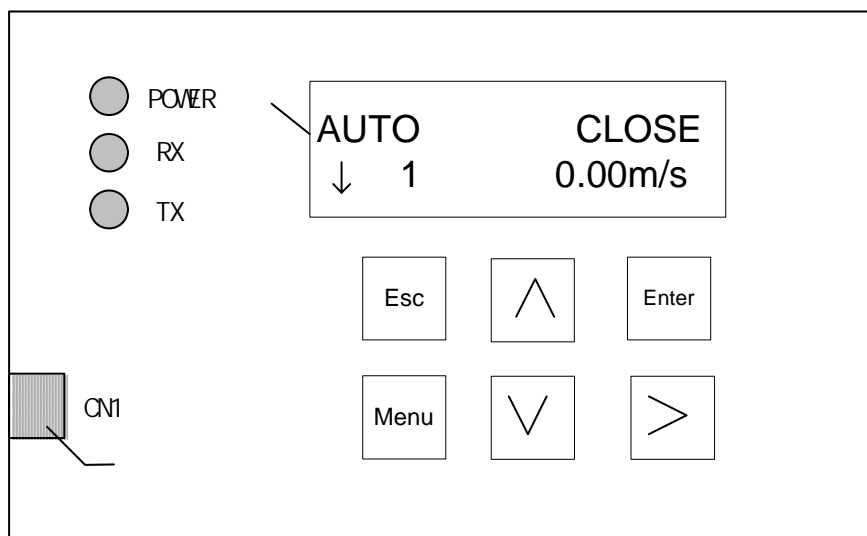

Keyboard definition:

“Menu” -- Return to the main interface in any case.

“Enter” -- Enter the submenu, confirmation keybutton

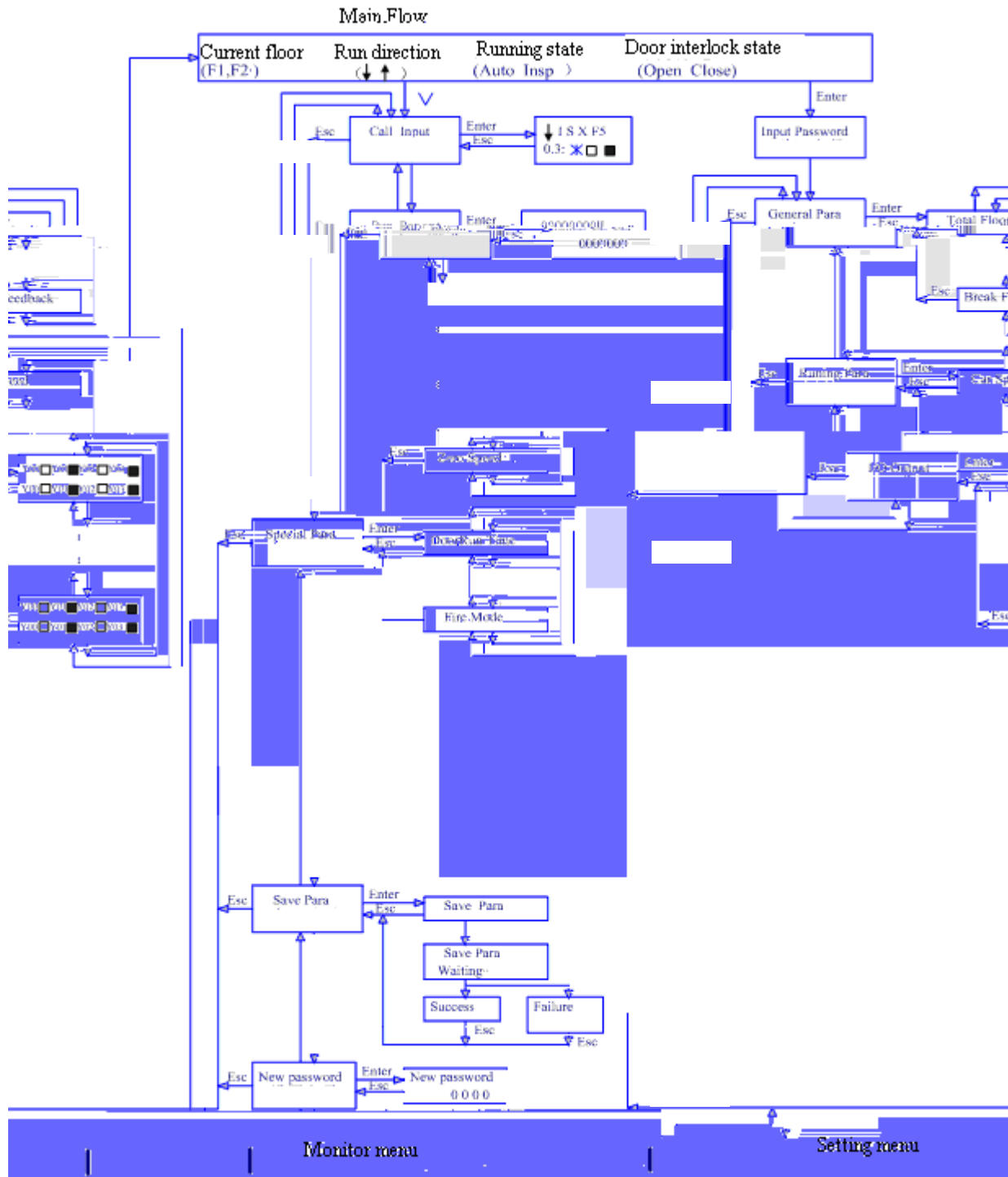

It is back to this interface once “Menu” button is pressed in any case except hoistway self-learning being processed (shows

4) Press “Enter” key to return back to the Step 1, until the password is correct, press “Enter” key to enter into Step 2.

Monitor menu, general parameter, running parameter and special parameter compose the basic factor of the elevator commissioning. The LCD indicator surfaces are divided to be “user class” and “factory class” according to the different requirements/CS6 CS 022 794



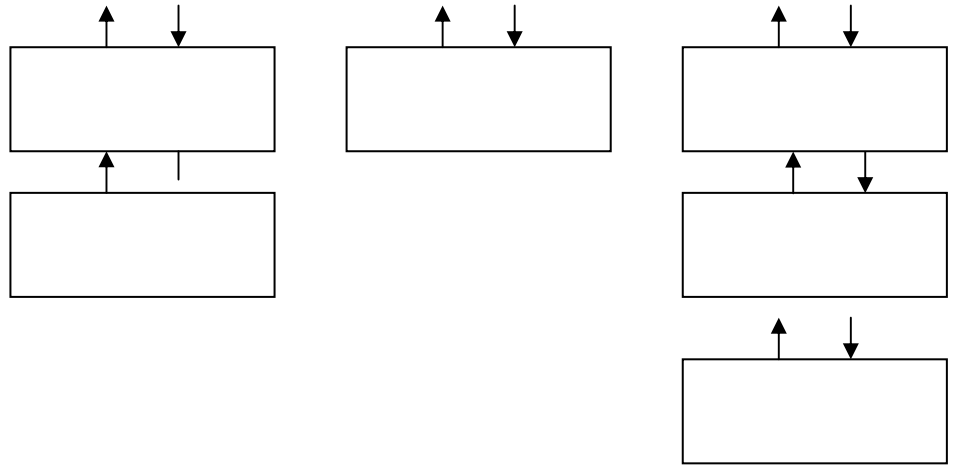

(2) Figure 3.3.3(b) Factory Menu

(1) **Monitor Menu:** Except call input, door open/close instruction could be entered, other parameters are only for read:

No	Menu	Note	Refer to
1	Call Input	It displays car call , landing call and inter selection	
2	Hbistway Data	It displays top and bottom limit and terminal position	
3	Floor Data	Leveling position and stop or not	
4	Speed Feedback	Motor speed (rpm) and elevator speed (m/s)	
5	Run Report	Accumulated running time	
6	Fault Report	The last 10 fault records	
7	Encoder Apprais	Valuate encoder interference and quality of pulse	
8	Input Apprais	Display the input interference and the inner state before the lastest 10 times stops	
9	Software Nb	Software version	
10	I/O Input	Input port state	
11	I/O Output	Output port state	
12	I/O Car Data	COP input and output state	

(2) **General parameter:**

--	--

17	Show Select	0	0~3	Set hall display code 0 7 segment 1 BCD code 2 Grey code 3 Point to Point 4 Ba
----	-------------	---	-----	---

(3)Running parameter:

No.	Menu	Default	Range	Note
1	Car Speed	1m/s	0.5-1.0m/s	Elevator speed
2	Motor Speed	---	1-9999r	Motor rated speed
3	Pulses	---	500-9999	Input pulse per revolve into main board
4	Brake On Time	50ms*	10~9990ms	Time delay from brake release to running
5	Brake Off Time	50ms*	10~9990ms	Time delay from zero speed to brake
6	Acc Time	0.6*	0.1-9.99	Acceleration inclination
7	Dec Time	0.6*	0.1-9.99	Deceleration inclination
8	Floor No. Chg Delay	0*	10~9990ms	Delay time from speed change to floor no. change
9	Zero Speed	5rpm*	0-9999	Zero speed value
10	Zero Time	10ms*	10-9990ms	Zero speed holding time
11	Brake Check Time	2000ms*	10-9990ms	Brake checking time
12	Beep Delay Time	0*	9990ms	Delay time from speed change to arrival chime output
13	Brake Err Count	5*	0-249	After brake error counts to this no., system will enter into protection state
14	KDY Err Count	5*	0-249	After KDY outputs count to this no and there is

7	Jog Select	0*	0/1	0 No jog output 1 Jog output
8	Control Mode	SHS*	WVF/SHS	WVF: VVVF control SHS AC-2 speed control
9	Multi Speed Give	0*	0~1m/s	Set speed (corresponding to inverter speed given).
10	Decel Distance	0*	0~10m	Deceleration distance
11	Over Time	45*	0~999s	Limit running time for one time
12	Manual Door	No*	Yes/No	No: Automatic door ,Yes Manual door
13	Single Call	No*	Yes/No	

User menu is open to all users. Factory menu is open to who have factory password.

Note:

1. When “enter” is displayed at bottom right corner on LCD, you may press “enter” key enter into

Hoistway Data Enter

2) Strike "Enter" key again to enter into hoistway switch position interface:

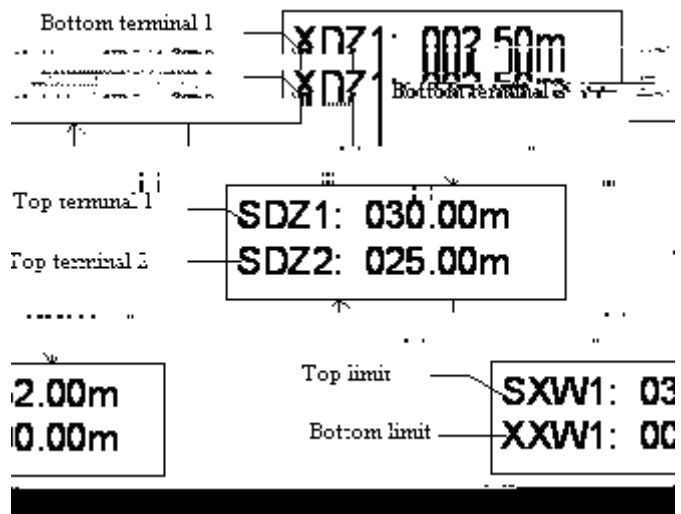

3) Select item by " " or " ";

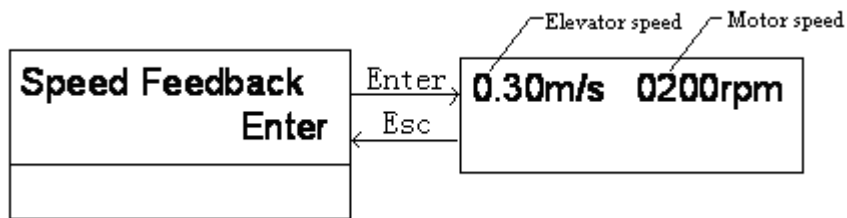

(5) Running record

It is accumulated time and times.



(6) Fault record

It records type and time of the latest 10 faults.

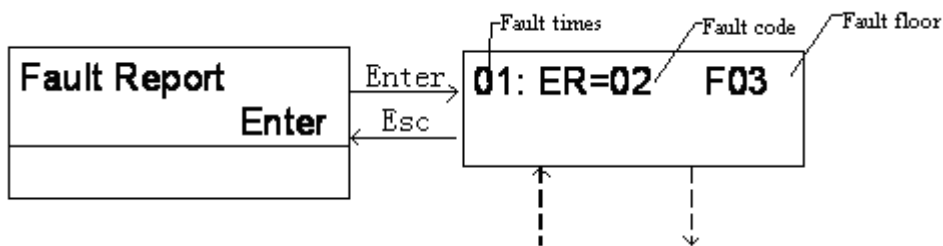

Fault record is saved in sequence according to the fault time. The latest fault record rank No.1;
Strike “ ” or “ ” to check the latest 10 fault records.

(7) Encoder evaluation



When elevator speed is steady, the bigger the data is , the worse the encoder signal is.

(8) Input signal evaluation

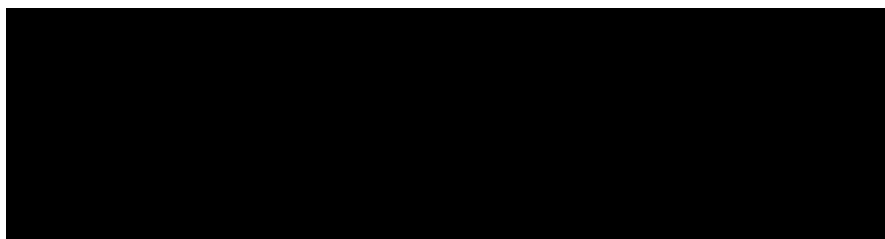

The first line is inner state before the latest 10 times stop(For factory commissioning);

The stick map indicates the interference degree: " " represent logic level of I/O port is "0", corresponding indicator light off; " " represents logic level of I/O port is "1", corresponding indicator light on;
 Stick represents logic level: High "1" Low "0";
 The more closer the number of 1 is to the number of 0, the more intense the interference is.
 Note: The logic level has nothing to do with input port level setting.

(9) Software No.

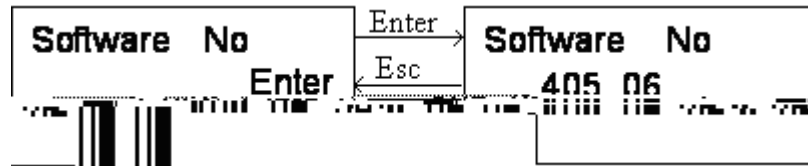

It is software version.

(10) Input signal (Point to Point display)

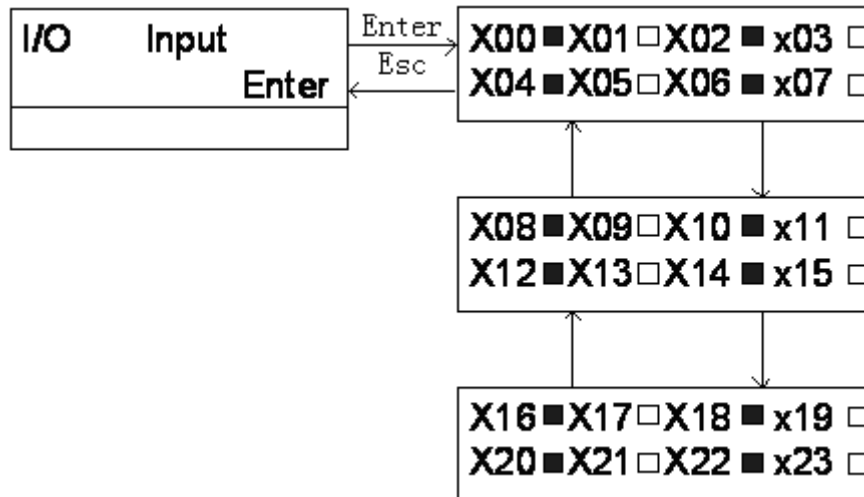

input 1, light on
 input 0, light off

Note: The logic level has nothing to do with input port level setting.

(11) Output signal (Point to Point display)

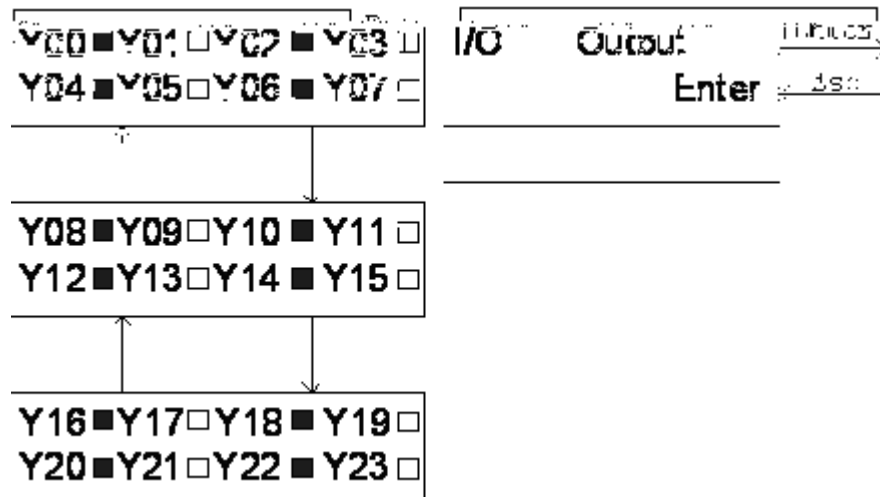

output 1, corresponding output relay close;

output , corresponding output relay open.

Note: The logic level has nothing to do with input port level setting.

(12) Car signal

Car signal includes door system input signal and COP input signal.

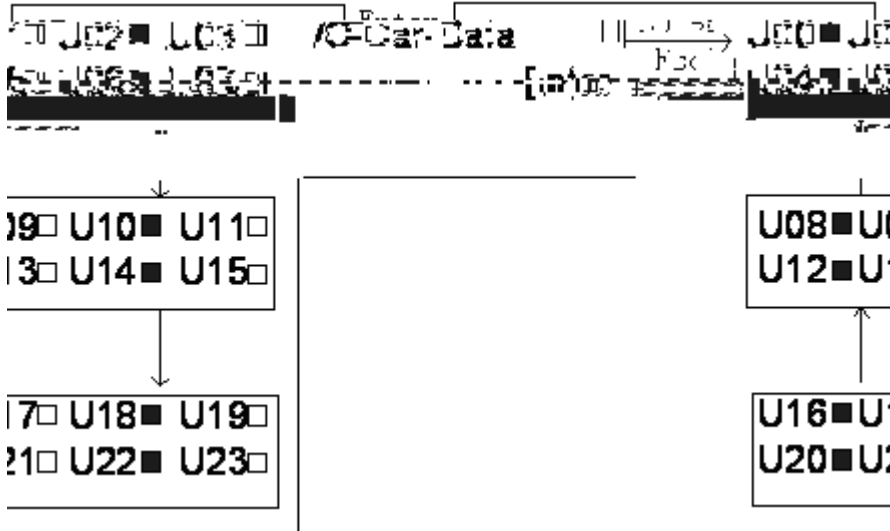

Table 3-5

No.	Definition	No.	Definition	No.	Definition
U00	Door close button 1	U07	Door open limit 1	U14	Light load switch
U01	Door open button 1	U08	Special switch	U15	Overload switch
U02	Door open button 2	U09	Door open holding switch	U16	No load (spare)
U03	Door close button 2	U10	Attendant switch	U17	Safety edge 2(For rear door)
U04	Door close limit 2	U11	Spare	U18	Safety edge 1
U05	Door open limit 2	U12	By pass switch	U19-U23	Spare
U06	Door close limit 1	U13	Full load switch		

input 1, input signal is valid

input 0, input signal is invalid

Note: The logic level “0” and “1” are related to input port level setting.

Before you set parameter, you must input correct password (user password / factory password).



When you enter into input password menu, ‘ ’ select bit, ‘ ’ and ‘ ’ modify data, if password is right, it will display general parameter menu, otherwise, it will displays the following:

Password error Enter

Strike "Enter" to input password again, until password is right, strike "Enter" to enter into General Parameter interface:

General para Enter

(5) Homing time

Note: Output relay (Inverter release) Y6 is ON for Fuji inverter.

(13) Two door mode (it is valid when two door mode >0)

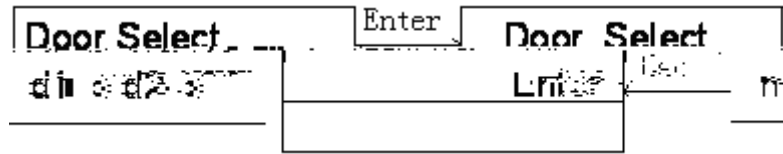

- n Floor No. It could be changed by “ , ” key.
 - d1 Front door. Select it by “>” key.
 - d2 Rear door. Select it by “>” key.
 - x=Y: this door act
 - x=N: this door doesn’t act.
- For example: two door elevator, on 6th floor, only front door act; on 7th floor, both front door and back door act.

Door Select
6 d1=Y d2=N

Door Select
7 d1=Y d2=Y

(14) Two door call distribution (It is valid when two door mode >1)

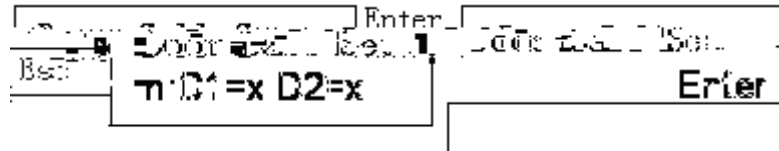

- n Floor No. It could be changed by “ , ” key.
 - d1 Front door landing call. Select it by “>” key.
 - d2 Rear door landing call. Select it by “>” key.
 - x=Y: this door distributes its landing call
 - x=N: this door doesn’t distribute its landing call
- It could be changed by “ , ” key.

For example: Two door elevator is total of 6 floors, on the 4th floor, there are two landing call boxes separately at the front door and rear door, on other floors, there is only one call box.

Door Call Set
4:D1=x D2=x

Front door landing call of 1st-6th floor is corresponding to landing call of 1st-6th floor, rear door down call of 4th floor is corresponding to up call of 6th floor , rear door down call of 4th floor is corresponding to down call of 7-6th floor.

(15) Multi-functional input set

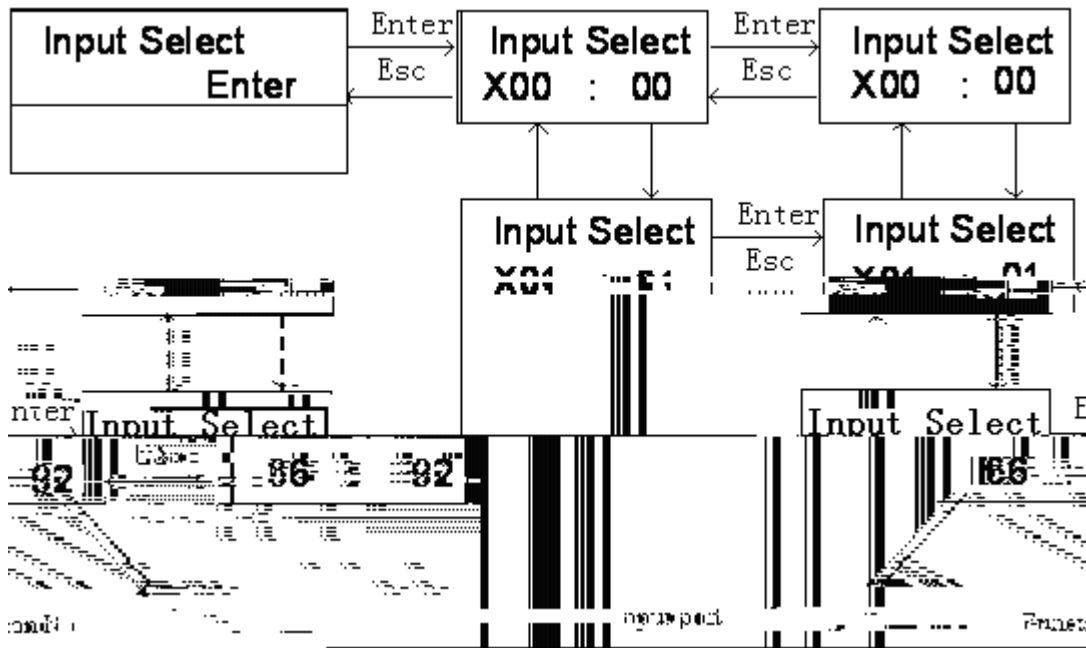

Multi-functional input function refers to chapter 2 I/O definition.

under “multi-function setting” if you want to set one function whose input points have been in existence the system will display all input points responding to this function. For example, provided, X1(input port) has been set “X1”(Function No.), after X0 being set “X1” and press “Enter” the system will display : X1 be set “X1”, so before X0 is sent “X1” The Com , X1 should be sent as other function No. or “99” (invalid).

(16) Multi-functional output set



Multi-functional output function refers to I/O definition.

(17) Display output code type

The default output of L5~L13 terminals is 7-segment code. It could be set BCD code , Grey code, etc.

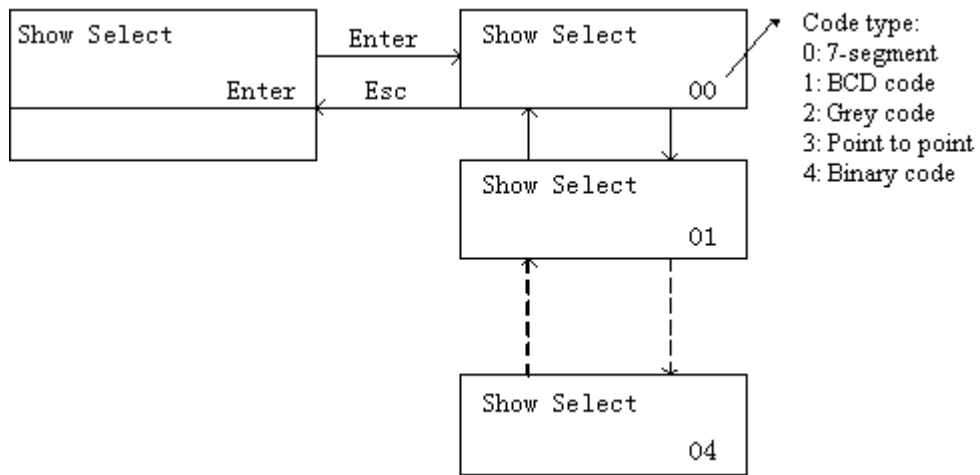

When output codt68type is set "1, 2, 3, 4"

Codt6	Terminal No.								
	Y18	Y19	Y20	Y21	Y22	Y23	Y24	Y25	Y26
1 2 46	Bit0	Bit1	Bit2	Bit3	Bit4	Bit5	Bit6	Inspection	"-"
3	1st floor	2nd floor	3rd floor	4th floor	5th floor	6th floor	7th floor	8th floor	"-"

It is used to set running parameters.

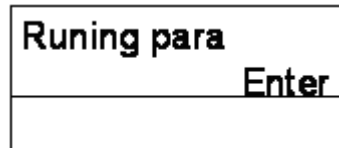

Strike "Enter" key to set parameters:

(1) Elevator rated speed

It is elevator rising speed undtr rated motor speed;

It could be set by nameplate of traction machine;

It also could be calculated by motor rated speed, traction ratio, sheave diameter.

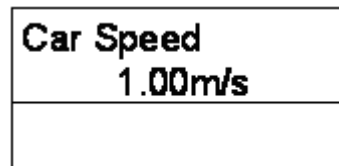

(2) Motor rated speed

It is set by nameplate.

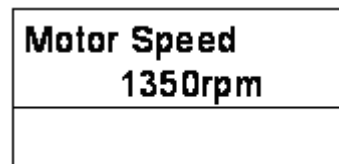

(3) Number of encoder pulse

The number of encoder pulse is input pulse to mainboard per revolve. When encoder is directly connected to the mainboard, it should be equal to the number of encoder pulse; otherwise it should be divided by frequency division ratio. (The max. frequency is 16kHz, if it is larger than 16kHz, it should be divided.)

Pulses 0600

Elevator rated speed, motor rated speed and number of encoder pulse are three important factors which determine if the elevator could run normally. If one of them is changed, hoistway learn must be performed before system normally runs.

AC-2 speed: Delay time from receipt of the speed change signal to floor No. change, floor account change; Multi-speed: Delay time from reaching the middle of one floor to floor No. change, floor account change.

Fir No. Chg Delay 0000ms

(9) Zero speed

When motor speed is lower than it, system regards elevator speed as zero, and output braking signal.

Zero Speed 0005r

5 r/m

(10) Zero speed holding time

When zero speed is kept for such a time, system regards elevator speed is really zero.

Zero time 0000ms

(11) Brake detection time

Brake detection time is the time from system outputting brake release instruction to system detecting if there is feedback input.

Brake Check Time 0000ms

(12) Arival chime delay time

It is the time from speed change to output of arrival chime signal.

Beep Delay Time 0000ms

(13) Brake detection times

Brake detection errors accounts to this number, and fault still exists, it

(14) KDY detection times

KDY detection errors accounts to this number, and fault still exists, it should be power off to restore.

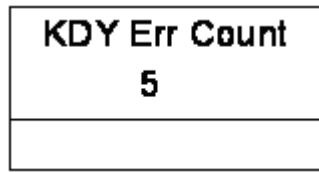

(15) Leveling adjustment

When elevator stops at different position for up/ down running on the same floor, adjusting it (up-running: higher and down-running: lower, reduce it, v.v.) Adjustment value is half of the leveling deflection. (Default: 50mm)



It is used to set special parameters.

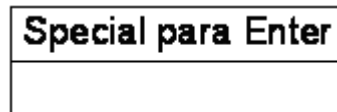

(1) Door open/close relay holding time

It is holding time of door open/close instruction. When there is no door open/close limit, door open/close time is determined by this parameter., When there are door open/close limi, it is a second longer than actual door open/close time.

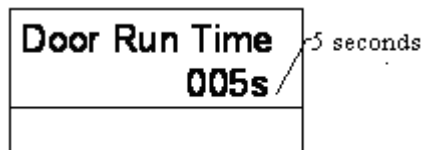

(2) Restore default



Yes: restore default When system parameters are disordered, you can restore default to debug again.

(3) Read parameter

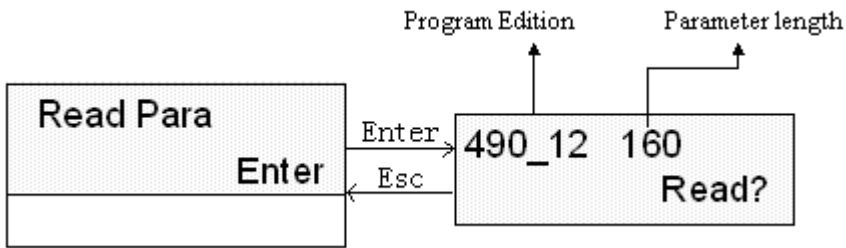

Read the parameters from mainboard to manual operation device and save them, manual operation device could save the latest read parameters, Success or not will be displayed as follows:

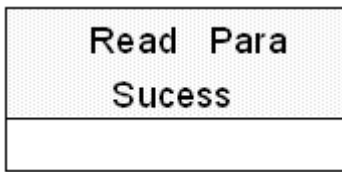

(4) Write parameter

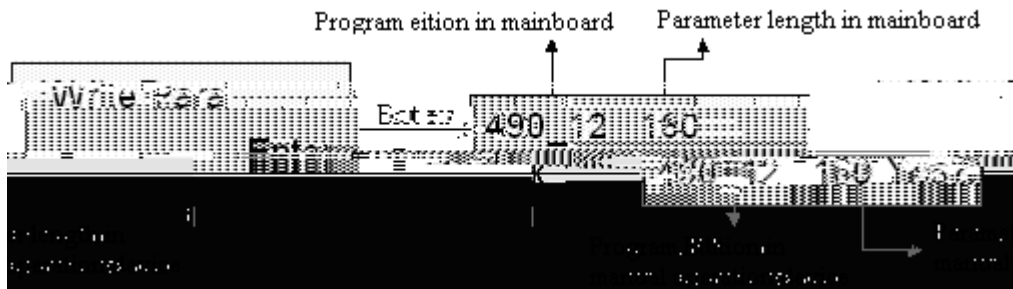

Write parameters from manual operation device to mainboard, but they are not saved, if you want to save them, please use save parameter menu. Success or not will be displayed as follows:

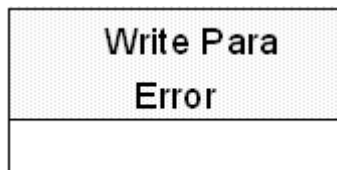

- Note: 1) When program edition of mainboard and manual operation device are different, the written parameters should be tested.
 2) Hoistway self-learning should be performed again after parameters being written in.
 3) If writing parameter is failed, turn off power of mainboard then turn on, restore previous parameters.

(5) Two door mode

When there are two doors at the same floor, door open/close mode can be sent by user's requirement.

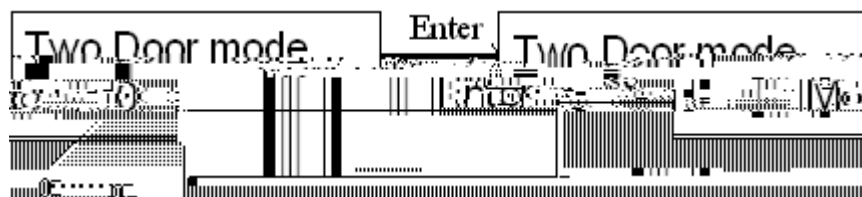

n=0 Single door mode;

n=1 Two door mode 1 only one door acts on one floor.

For example:

3floors/3stops elevator, only front door acts on 1st and 3rd floor, only rear door acts on 2nd floor;

n=2 Two door mode 2 two doors both act on one or more floors, it works as following logic:

- On two door floor, only one door could be operated at same time, and only after the door interlocks again, the other door could be operated;
- On two door floor, when one door close, if another door's close limit is invalid, two doors close;
- In inspection state, whatever it is two door or not, two door both can open, but they can't open at same time;

n=3 4 Two door mode 3,4 , two doors can both act on some floors (at least one floor has two doors) it works as following logic:

- On two door floor, two doors open/close at same time anytime except in inspection state.

n=5 Two door mode 5, two doors can both act on some floors (at least one floor has two doors) it works as following logic:

- On two door floor, elevator stops by car call, two doors open, otherwise only the door at landing call side will open, door open/close button and landing call only correspond to that door.

Under two door mode 2~5, front door and rear door correspond to different landing call and car call, for N floor elevator, landing call (car call) input "1 ~ N" correspond to front door of 1 ~ N floor, landing call(car call) input "N+1 ~ N+N" correspond to rear door of 1 ~ N floor.

(6) Fire mode

When fire mode is 1, elevator only returns to fire floor when fire emergency.

If fire mode is 0, you should consider whether there are enough firefighting devices, otherwise it will incur accident.



(7) Jog output selection

When Drive is set "Yes", there is jog output. If "No", there is no jog output.

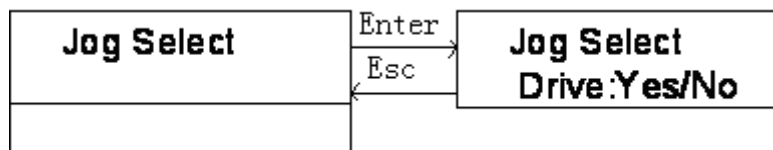

(8) Control mode selection

When elevator control mode is multi-speed, it should be set "WVF"; when control mode is AC-2 speed, it should be set "SHS", default is SHS.

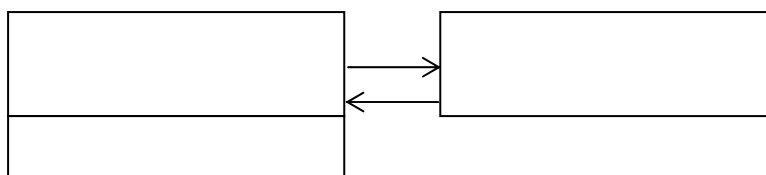

(9) Multi-speed set

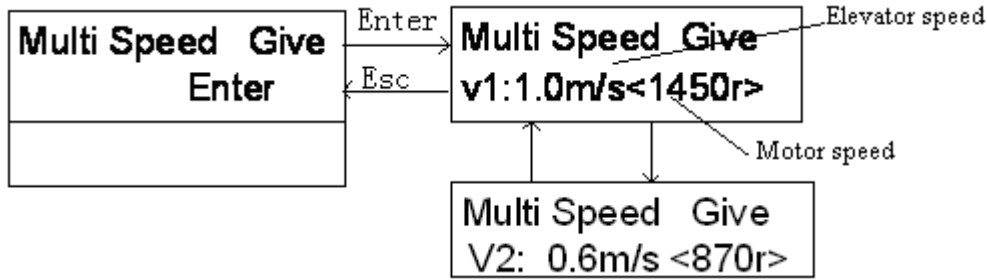

When multi-speed given is released, it is necessary to set multi-speed value and speed change distance.

A table of multi-speed value and speed change distance corresponding to different elevator speed is at follows (only for reference)

Table 3-10

Elevator speed Value	1.0m/s	
	Speed V	Distance S
Parameter V1/S1	1m/s	1.3m
V2/S2	0	0

Note: 1) V1~V2: From high speed to low speed (V1 is set by elevator rated speed);

2) S1~S2: Speed change distance corresponding to V1~V2, S1~S2 will influence the leveling accuracy;

For example, when elevator speed is 1.0m/s, set max. speed V1 "1m/s", set V2 "0"; Control system select different speed according to different target distance to reach max. efficiency and comfort.

3) Inspection, crawl and self-learning speed can be set by corresponding parameter in inverter;

4) Once the speed value is set, LCD indicator will display the corresponding motor speed, multi-speed value parameter of inverter should be set by this value. (Unit: rpm)

V1~V2 are for system inner calculation, only changing the parameter can't lower the elevator actual speed.

Self-learning	0	0	
Crawl	0	1	1
Medium speed 2 V2	1	1	0
High speed V1	1	1	1

Note: Please follow the table above to set multi-speed value of inverter.

(10) Deceleration distance

Deceleration distance is the distance from speed change position to leveling position.

In multi-speed mode, in order to avoid braking at non-zero speed and long crawling time, deceleration distance is different for different speed;

It should be adjusted by test.

Table 3-10 is only for reference.

(11) Running overtime set

To avoid damage to system caused by rope slide or car box block, the time from start to stop should be limited . This parameter is the time limit;

If running time of one time exceeds the value, system will enter into protection state at once, and only after power is turned on again, system can get out from protection state;

User should set the parameter according to elevator speed and building height. Default is 45s.

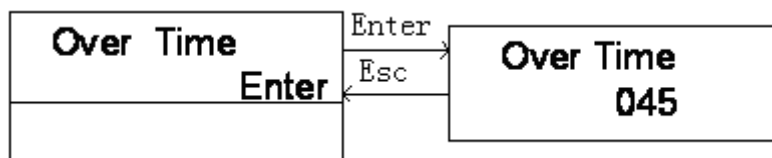

(12) Manual door selection

Default is automatic door, when elevator door is manual door, set the parameter "Yes".



(13) Single collective selective set

Default is full collective selective, when it is set "Yes", system is of single collective selective.

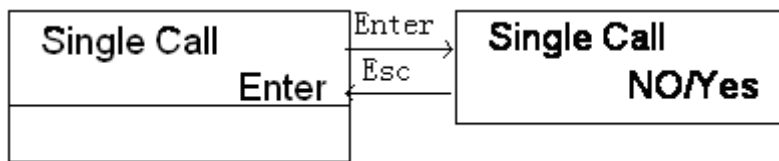

(14) Special function selection

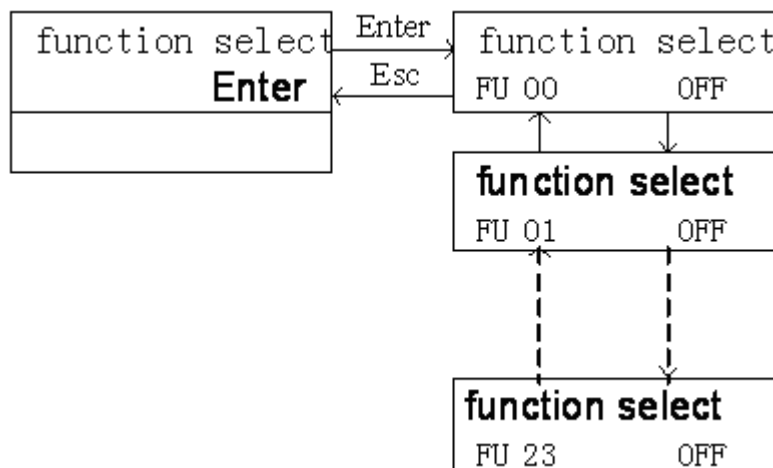

To satisfy clients' special requirement, there are some special functions in the microprocessor system, they are optional.

Table 3-12 Special function

Function No.	Instruction
FU00	After elevator stops, system regards current floor as basic floor, if there is no landing car and car call on the floors above the basic floor in previous running direction, all registered car call will be canceled.
FU01	For inner test
FU02	When elevator runs to crawl section, inverter speed is given 0 after encountering double leveling zone switch; otherwise inverter speed is given 0 after encountering single leveling zone switch, it is default.
FU03~FU23	Spare

AC-2 speed control, time-speed figure for normal running

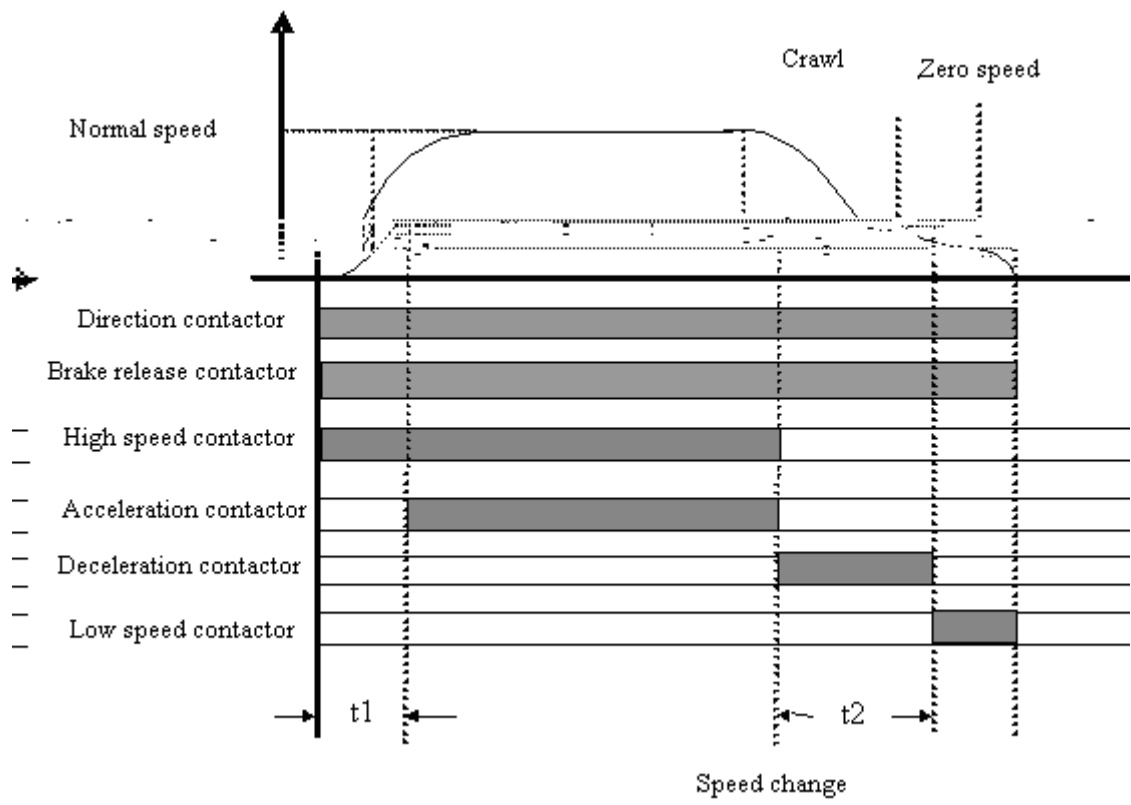

t_1 : Acceleration contactor switch time (acceleration time), t_2 : Deceleration contactor act time (deceleration time), the two parameters can be set in running parameter menu "Acc On Time"(t_1) and "Dec On Time" (t_2).

Code	Note	Process
Er0	Parameters are not initialized or parameter zone has fault	Saving parameter operation can solve the problem, if can't,

		contact with factory
Er1		
Er2	Door inter-lock fault Door inter-lock circuit open when elevator running	Check door interlock circuit and door cam
Er3	Inverter fault	Check inverter
Er4	Direction contactor fault, direction given is different with the feedback of direction contactor	Check the direction contactor connection. Direction feedback should be connected to NO contacts of direction contactor.
Er5	Brake release fault, system doesn't receive the feedback from brake contactor or brake detection switch	Check brake detection switch and connection , if there is no such switch, Brake Feedback should be set "OFF".
Er6	During running, leveling zone signal is valid all the time.	Check leveling zone signal and inductive switch
Er7	During runnin, input pulse No. to control unit is too small	Check pulse input circuit od main control unit and encoser connection.
Er8		Please contact with factory
Er9	KDY/KKC fault, KDY/KKC output instruction is different with the feedback	Check KDY/KKC output , feedback circuit and KDY/KKC contactor
Er10	Emergency stop circuit open	Check emergency stop circuit
Er11	Elevator doesn't detect leveling zone signal	Check leveling zone signal circuit and inductive switch
Er12	Over top limit	Check encoder and related circuit.
Er13	Over bottom limit	Check encoder and related circuit.
Er14	VVVF Floor counter fault. When this fault happens, elevator will run slowly to the bottom floor and adjust the position.	Check encoder and related circuit check leveling zone circuit. Typical fault: leveling zone signal tingle or rope slide
	AC-2	KMC feedback is inconsistent
Er15		

	inconsistent with the state of circuit.	ports on mainboard.
Er28	Terminal adhere protection	Check terminal signal input
U	Door open default, when door open limit is valid or it is door open time, door interlock doesn't open. It displays " □ ".	Check door open output relay, door open limit, door interlock circuit or if door interlock is short-circuited.
N	Door close default, when door close limit is valid or it is door close time, door interlock doesn't close. If the fault happens, system will open the door, then close the door again; Repeat 5 times, if the interlock still doesn't close, system won't close door and display fault code. It displays " □ ".	Check door close output realy , door close limit , door interlock circuit.

No.	code	note	process
1	LER=0	System running protection	Strike 'esc', check fault record
2	LER=1	Pulse input phase reverse	Exchange A phase and B phase
3	LER=2	Bottom terminal 1 input repeat	Bottom terminal 1 fixed in error or tingle
4			

5			
6			
7			
8			
9			